

**FOR ADDITIONAL DETAILS AND SPECS SEE DWG A95214 SHEETS 1 TO 7**

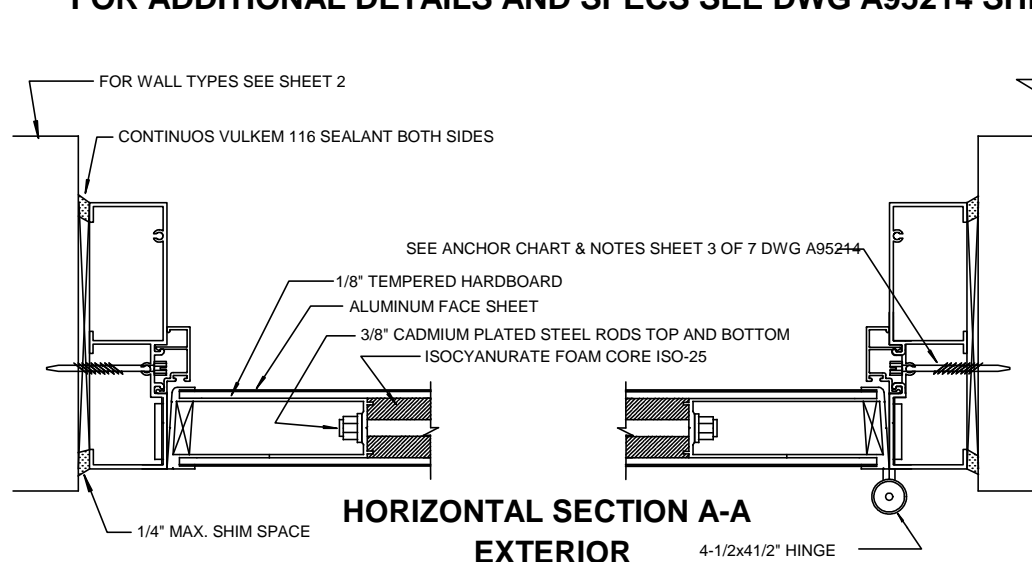

**HORIZONTAL SECTION A-A  
EXTERIOR**

**FR600S**

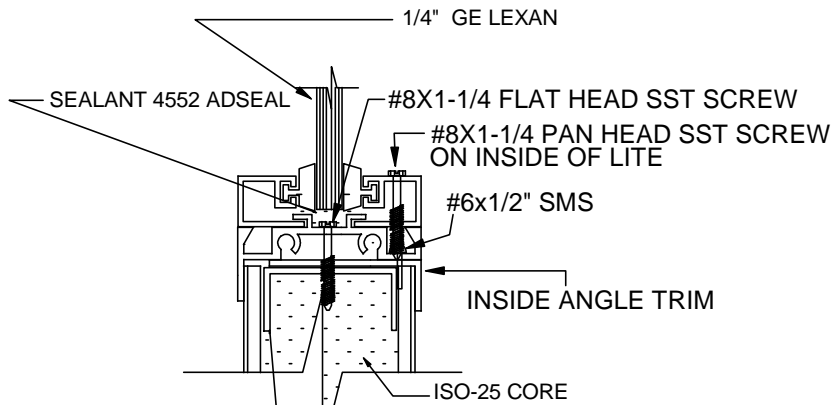
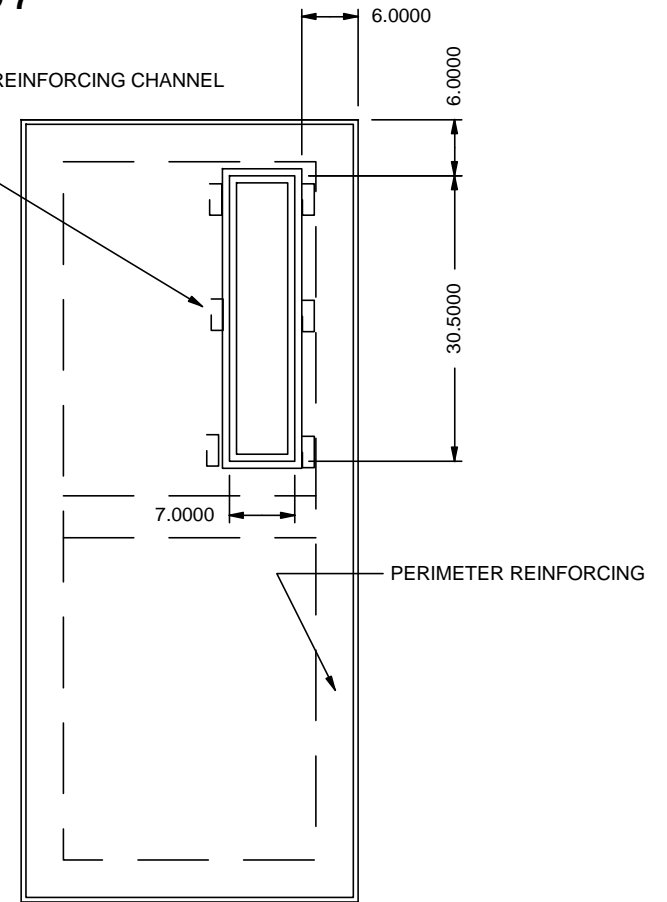

ALUMINUM REINFORCING CHANNEL  
3 PER SIDE ONLY

**LITE DETAIL**



ALUTECH CORPORATION  
8548 NW 64th STREET  
MIAMI, FL 33166  
305/593-2080

IMPACT WINDOW INSTALLATION  
SIZE 7" X 30 1/2"

DATE: 09/11/02	DRAWN BY: A.P.
DWG No.: A022056	SHEET No.: 1 OF 1

JOB No.: 2056